



Midlum

150.08/B 4X2R



Your perfect transport solution

Britcom International Ltd

York Road

Market Weighton

YORK

YO43 3QX

Tel: +44 (0) 1430 871010

Fax: +44 (0) 1430 872492

Email: sales@britcom.co.uk

BRITCOM
INTERNATIONAL

www.britcom.co.uk



Midlum

150.08/B 4X2R

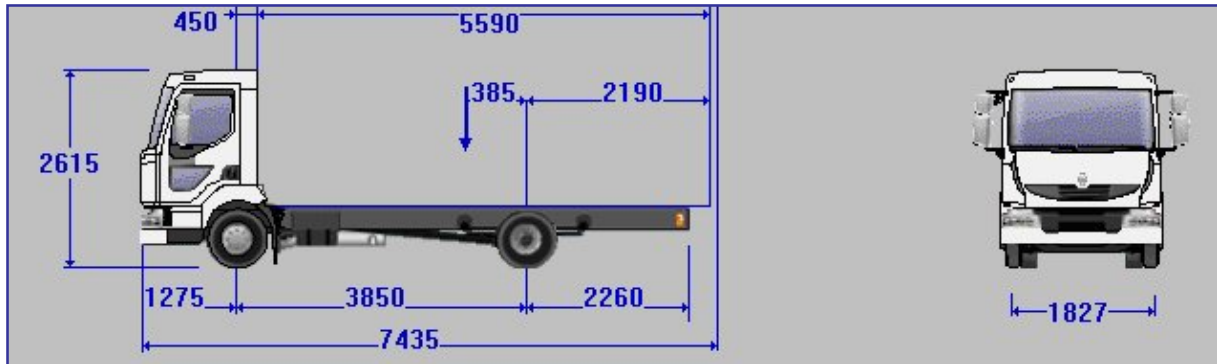

ENGINE dCi 4 4B

Diesel 4 cylinders in line
 Common Rail injection with electronic management
 Turbo charged and intercooled
 Power: 112 kW (152 hp) at 2400 rpm
 Torque: 550 Nm (406 lbf.ft) at 1200-1600 rpm
 Bore: 102mm
 Stroke: 126mm
 Displacement: 4.12 litres
 Cooling fan thermostatically controlled

CLUTCH

Single plate hydraulic: dia 362mm

GEARBOX

ZF S5-42 GEARBOX
 5 forward and 1 reverse speeds fully synchromesh

STEERING

Integral hydraulic power assistance

FRONT AXLE

FRONT AXLE: E46AB
 Front axle plating: 3400kg

REAR AXLE

REAR DRIVE AXLE: P 669
 Single reduction: Hypoid
 Max load on rear axle: 5200kg

WHEELS & TYRES

Tyres 215/75 R 17.5
 Disc wheels 17.5 x 6.00 – 6 – 124 M18 E

FUEL TANK

Plastic 130 litres capacity with locking filler cap

WEIGHTS & DIMENSIONS

WEIGHTS		
Kerb Weight Rear	kg	830
Kerb Weight Front	kg	2165
Kerb Weight Total	kg	2995
Maximum Load Front	kg	3400
Maximum Load Rear	kg	5200
Body/Payload Allowance	kg	4505
DIMENSIONS		
Wheelbase (F)	mm	3850
Max Overall Length (Z)	mm	7435
Unladen Cab Ht (excl side deflect)	mm	2615
Max Cab Width at wings	mm	2140
Chassis Length	mm	7385
Frame Rear Overhang (N)	mm	2260
Body Length Max (W)	mm	5590
Front Overhang	mm	1275
Frame Width Front	mm	850
Frame Width Rear	mm	850

BRAKING EQUIPMENT

Full air braking system with independent twin circuits
 Front & Rear ventilated discs
 Anti lock braking system
 Parking brake
 Automatically self adjusting

ELECTRICAL EQUIPMENT

24 Volts – 2 batteries of 12 V – 125 Ah.
 Alternator: 6 - Amp

SUSPENSION

FRONT:
 Parabolic leaf springs
 Telescopic shock absorbers
 Anti-roll bar

REAR:
 Parabolic suspension
 Anti-roll bar